

## C6097A,B Pressure Switches

### PRODUCT DATA



### APPLICATION

The C6097 Pressure Switches are safety devices used in positive-pressure or differential-pressure systems to sense gas or air pressure changes.

### FEATURES

- For use with natural gas, liquid propane (LP) gas, or air.
- Diaphragm-actuated safety-limit switch.
- Switch can be wired to turn on alarm.
- C6097A models break control circuit at setpoint on pressure fall.
- C6097B models break control circuit at setpoint on pressure rise.
- Lockout with manual reset and recycle options.
- Lockout models have external manual reset button.
- Removable transparent cover protects scaleplate and adjusting knob.
- Pipe tapings allow selection of positive pressure, differential pressure (air only) or venting connections (NPT mount only).
- 1/4 in. NPT or flange mount models for direct mounting to Honeywell Integrated Valve Train.
- Optional switch position indicator lamp available.
- IP54 enclosure standard.
- Ranges: 0.4 to 5 in. wc, 3 to 21 in. wc, 12 to 60 in. wc or 1.5 to 7 psi.
- Surge orifice.

### Contents

Application .....	1
Features .....	1
Specifications .....	2
Ordering Information .....	2
Installation .....	4
Wiring .....	5
Settings and Adjustments .....	5
Operation and Checkout .....	6



## SPECIFICATIONS

### Models:

C6097A Pressure Switch: Breaks a circuit when pressure falls to scale setting. See Table 1.

C6097B Pressure Switch: Breaks a circuit when pressure rises to scale setting. See Table 1.

Table 2 shows switch ratings and Table 3 shows alternate electrical ratings when used with Honeywell Flame Safeguard Programmers.

**Minimum Ambient Temperature:** -40°F (-40°C).

**Maximum Ambient Temperature:** 140°F (60°C).

### Connections (Depending on Model):

1/4-18 NPT tapping for main or high-pressure connection.  
1/8-27 NPT tapping for vent or low-pressure connection (air only).

Flange mount for connection to Honeywell Integrated Valve Train (internal vent only, no external connections).

### Scale Range:

0.4 to 5 in. wc (0.10 kPa to 1.25 kPa).  
3 to 21 in. wc (0.75 to 5.23 kPa).  
12 to 60 in. wc (3.0 kPa to 15 kPa).  
1.5 to 7 psi (10.3 kPa to 48 kPa).

### Approvals:

Underwriters Laboratories Inc. listed.  
Canadian Standards Association listed.  
Factory Mutual: Approved.  
Industrial Risk Insurers: Acceptable.  
CSD-1 AFB: Acceptable.

### Accessories:

32003041-001 C6097 Cover for manual reset models.  
32003040-001 C6097 Cover for recycle models.  
32003039-001 Position Indication Lamp Kit.

**Dimensions:** See Fig. 1 and 2.

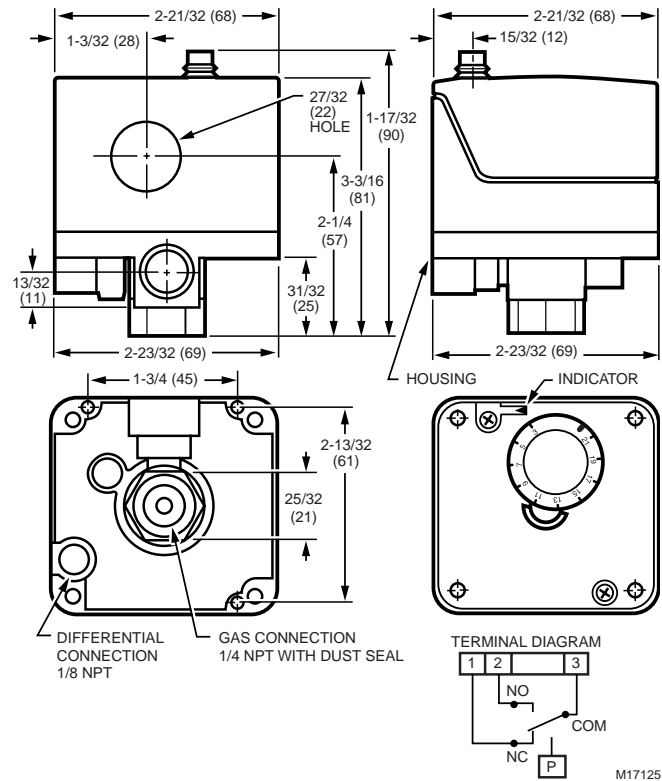

**Fig. 1. C6097 1/4 in. NPT Mount dimensions in in. (mm).**

## ORDERING INFORMATION

When purchasing replacement and modernization products from your TRADELINE® wholesaler or distributor, refer to the TRADELINE® Catalog or price sheets for complete ordering number.

If you have additional questions, need further information, or would like to comment on our products or services, please write or phone:

1. Your local Home and Building Control Sales Office (check white pages of your phone directory).
2. Home and Building Control Customer Logistics  
Honeywell Inc., 1885 Douglas Drive North  
Minneapolis, Minnesota 55422-4386 (612) 951-1000

In Canada—Honeywell Limited/Honeywell Limitée, 155 Gordon Baker Road, North York, Ontario M2H 3N7.

International Sales and Service Offices in all principal cities of the world. Manufacturing in Australia, Canada, Finland, France, Germany, Japan, Mexico, Netherlands, Spain, Taiwan, United Kingdom, U.S.A.

Table 1. Pressure Switch Model Selection.

Model	Operating Pressure Range	Manual Reset Differential		Non-Manual Reset Differential		Differential Type	Maximum Rated Pressure (continuous) (psi)	Manual Reset	Media <sup>a</sup>	Switch Action at Setpoint	Comments
		Maximum at Minimum Setpoint	Maximum at Maximum Setpoint	Nominal	Maximum						
C6097A1004	0.4 to 5 in. wc	—	—	0.16 in. wc	0.24 in. wc	Additive	2.9	No	Air/Gas	Breaks N.O. to C. connection on pressure fall.	1/4 in. NPT Mount
C6097A1012	3 to 21 in. wc	2.4 in. wc	4.2 in. wc	—	—		4.3	Yes	Air/Gas		1/4 in. NPT Mount
C6097A1020	3 to 21 in. wc	2.4 in. wc	4.2 in. wc	—	—		4.3	Yes	Air/Gas		Flange Mount
C6097A1038	12 to 60 in. wc	10 in. wc	12 in. wc	—	—		4.8	Yes	Air/Gas		1/4 in. NPT Mount
C6097A1046	12 to 60 in. wc	10 in. wc	12 in. wc	—	—		4.8	Yes	Air/Gas		Flange Mount
C6097A1053	3 to 21 in. wc	—	—	0.24 in. wc	0.48 in. wc		4.3	No	Air/Gas		1/4 in. NPT Mount
C6097A1061	3 to 21 in. wc	—	—	0.24 in. wc	0.48 in. wc		4.3	No	Air/Gas		Flange Mount
C6097A1079	12 to 60 in. wc	—	—	1.1 in. wc	2.4 in. wc		4.8	No	Air/Gas		1/4 in. NPT Mount
C6097A1087	12 to 60 in. wc	—	—	1.1 in. wc	2.4 in. wc		4.8	No	Air/Gas		Flange Mount
C6097A1095	0.4 to 5 in. wc	0.6 in. wc	1.0 in. wc	—	—		2.9	Yes	Air/Gas		1/4 in. NPT Mount
C6097A1103	1.5 to 7 psi	1.1 psi	1.4 psi	—	—		9.3	Yes	Air/Gas		Flange Mount
C6097A1111	1.5 to 7 psi	1.1 psi	1.4 psi	—	—		9.3	Yes	Air/Gas		1/4 in. NPT Mount
C6097A1129	1.5 to 7 psi	—	—	0.1 psi	0.3		9.3	No	Air/Gas		Flange Mount
C6097A1137	1.5 to 7 psi	—	—	0.1 psi	0.3		9.3	No	Air/Gas		1/4 in. NPT Mount
C6097A1210	0.4 to 5 in. wc	—	—	0.16 in. wc	0.24 in. wc		2.9	No	Air/Gas		Flange Mount
C6097A1228	0.4 to 5 in. wc	—	—	—	—		2.9	Yes	Air/Gas		Flange Mount
C6097B1002	12 to 60 in. wc	10 in. wc	12 in. wc	—	—	Subtractive	4.8	Yes	Air/Gas	Breaks N.C. to C. connection on pressure rise.	1/4 in. NPT Mount
C6097B1010	12 to 60 in. wc	10 in. wc	12 in. wc	—	—		4.8	Yes	Air/Gas		Flange Mount
C6097B1028	3 to 21 in. wc	2.4 in. wc	4.2 in. wc	—	—		4.3	Yes	Air/Gas		1/4 in. NPT Mount
C6097B1036	3 to 21 in. wc	2.4 in. wc	4.2 in. wc	—	—		4.3	Yes	Air/Gas		Flange Mount
C6097B1044	1.5 to 7 psi	1.1 psi	1.4 psi	—	—		21.0	Yes	Air/Gas		Flange Mount
C6097B1051	1.5 to 7 psi	1.1 psi	1.4 psi	—	—		21.0	Yes	Air/Gas		1/4 in. NPT Mount
C6097B1069	3 to 21 in. wc	—	—	0.24 in. wc	0.48 in. wc		4.3	No	Air/Gas		Flange Mount
C6097B1077	12 to 60 in. wc	—	—	1.1 in. wc	2.4 in. wc		4.8	No	Air/Gas		Flange Mount
C6097B1085	12 to 60 in. wc	—	—	1.1 in. wc	2.4 in. wc		4.8	No	Air/Gas		1/4 in. NPT Mount
C6097B1093	1.5 to 7 psi	—	—	0.1 psi	0.3 psi		21.0	No	Air/Gas		Flange Mount
C6097B1101	1.5 to 7 psi	—	—	0.1 psi	0.3 psi		21.0	No	Air/Gas		1/4 in. NPT Mount
C6097B1119	3 to 21 in. wc	—	—	0.24 in. wc	0.48 in. wc		4.3	No	Air/Gas		1/4 in. NPT Mount

<sup>a</sup> Acceptable media: Natural gas, liquid propane (LP) gas, and air.

**Table 2. Switch Ratings (Amperes)**

120/240 Vac, 50/60 Hz		
Inductive	Full Load	3.0
	Locked Rotor	18.0
Resistive		5.0

**Table 3. Alternate Electrical Ratings when used with Honeywell Flame Safeguard Programmers.**

Device	Rating
Ignition Transformer	540 VA
Pilot Valve	50 VA
Main Valve	400 VA with 2-1/2 times inrush.

### When Installing this Product...

1. Read these instructions carefully. Failure to follow them can damage the product or cause a hazardous condition.
2. Check the ratings given in the instructions and on the product to make sure that the product is suitable for your application.
3. Installer must be a trained, experienced service technician.
4. After installation is completed, check out product operation as provided in these instructions.

### **⚠️ WARNING**

**Electrical Shock Hazard.**

**Can cause serious personal injury or death.**

Disconnect power supply before beginning installation. More than one disconnection can be involved.

### Mounting

NOTE: On flange models, remove the label holding the O-ring in place and make sure O-ring seal is in place before mounting the pressure switch on the valve.

The C6097 models allow NPT or flange (directly to valve) mounting. The NPT models have a hexagonal fitting with a 1/4 in. NPT tapping, which is the high pressure connection, in differential applications. The bleed fitting is 1/8 in. NPT tapped. In differential pressure control applications using air only, connect the lower pressure to the bleed fitting. See Fig. 1 and Table 1. In applications using combustible gases, vent the bleed tapping according to applicable standard code or jurisdictional authority.

C6097 models with flange mount can be fitted directly to Honeywell Integrated Valve Train (model specific). See Fig. 2 and Table 1. The flange mount models vent internally, with no external tap.

Mount the C6097A,B in any position.

### Leak Check

After installation, perform a leak check on the pressure switch:

1. Turn on main gas. Make sure gas has reached the pressure switch (e.g., high gas pressure switch)
2. Check installation for gas leaks using a gas leak detector or a soap solution.

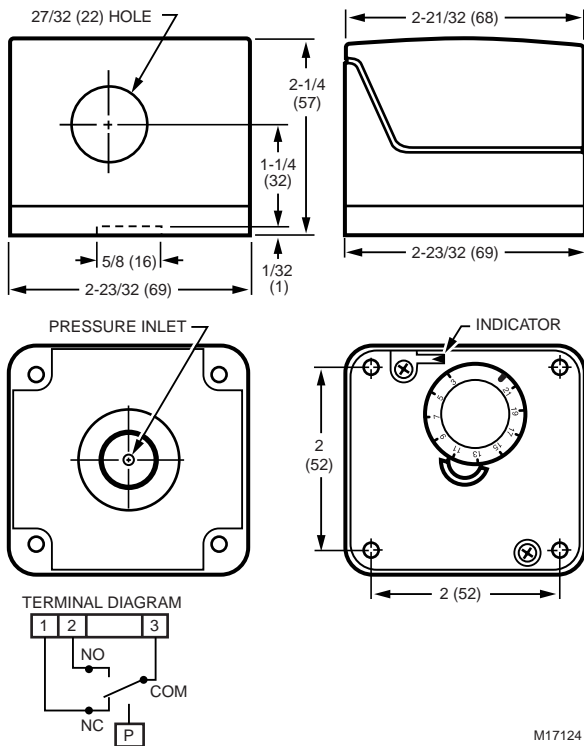

**Fig. 2. C6097 Flange Mount dimensions in in. (mm).**

## INSTALLATION

### **⚠️ WARNING**

**Explosion or Fire Hazard.**

**Can cause severe personal injury, death or property damage.**

Observe all safety requirements each time a control is installed on a burner.

## WIRING

### **⚠ WARNING**

**Electrical Shock Hazard.**  
**Can cause serious personal injury or death.**  
 Disconnect power supply before beginning installation.  
 More than one disconnection can be involved.

Make sure that all wiring agrees with all applicable local codes, ordinances and regulations. An opening is provided to accommodate rigid conduit or armored cable for line voltage operation (see Fig. 3 and 4). Do not overload the switch contacts (see Switch Ratings in the Specifications section). The switching schematic is shown in Fig. 5.

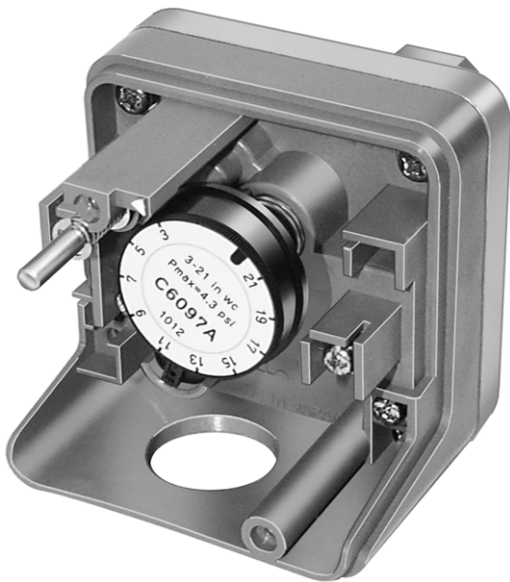



**Fig. 3. C6097 (manual reset switch model) with cover removed.**

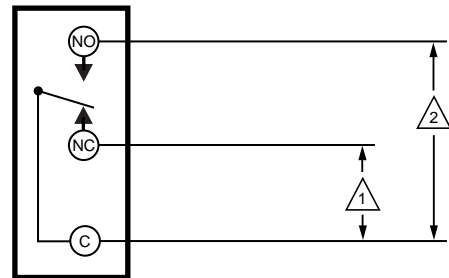

**Fig. 4. C6097 (recycle model) with cover removed.**

## SETTINGS AND ADJUSTMENTS

### Pressure Setpoint Adjustment

To adjust the pressure setting, turn the setpoint adjustment dial (Fig. 3, 4 and 5) clockwise  to increase the pressure setting and counterclockwise  to decrease the pressure setting.



**1** C6097A BREAKS C-NO, MAKES C-NC ON PRESSURE FALL. MANUAL RESET MODELS LOCK OUT.

**2** C6097B BREAKS C-NC, MAKES C-NO ON PRESSURE RISE AND LOCKS OUT.

M17123

**Fig. 5. C6097 schematic.**

## OPERATION AND CHECKOUT

### Operation

The manual reset C6097A diaphragm actuates the snap-acting switch to break a control circuit and lock out when pressure falls to the scale setting. The recycle C6097A models recycle automatically when the control circuit returns to scale setting plus differential.

The manual reset C6097B diaphragm actuates the snap-acting switch that breaks a control circuit and locks out when the pressure rises to the scale setting. The recycle C6097B models recycle automatically when the control pressure falls to the scale setting minus differential.

### Manual Resetting

The C6097A manual reset models lock out when pressure falls to the scale setting and require manual resetting after the pressure rises to scale setting plus differential to resume normal operation.

The C6097B manual reset models lock out when pressure rises to the scale setting and require manual resetting after the pressure falls to scale setting minus the differential to resume normal operation.

To reset, once normal operating pressure is restored, push the reset button in as far as it goes, then release.

#### **IMPORTANT**

*Lockout models cannot be made to recycle automatically by permanently holding in the reset lever.*

### Checkout

#### **C6097 Gas Fuel Application**

1. Set cutoff pressure.
2. Open main supply line. Depress reset lever on lockout models until switch makes control circuit.
3. Set controller and limit switch to call for heat.
4. For C6097A: Close the manual gas shutoff valve. C6097 should open control circuit when pressure reaches cutoff point.  
For C6097B: Open the manual gas shutoff valve, wait a few minutes for the pressure to rise; then lower the scale setting until the switch breaks control circuit and locks out.
5. For C6097A: Open the shutoff valve, return the pressure switch to its original setting and press the reset button (if necessary).  
For C6097B: raise setting to normal and press reset button (if necessary).
6. Allow system to operate through at least one complete cycle to make sure all components are functioning properly.

#### **C6097A Air Application**

1. Set cutoff pressure.
2. Turn on fan.
3. Block fan inlet or filter area. Switch should break control circuit when pressure drops to cutoff point. Manual reset models lock out.
4. Remove obstruction. Press reset lever (manual reset models) and allow system to operate through at least one complete cycle to be sure all components are functioning properly.



**Home and Building Control**

Honeywell Inc.  
Honeywell Plaza  
P.O. Box 524  
Minneapolis, MN 55408-0524

**Honeywell Latin American Region**

480 Sawgrass Corporate Parkway  
Suite 200  
Sunrise FL 33325

**Home and Building Control**

Honeywell Limited-Honeywell Limitée  
155 Gordon Baker Road  
North York, Ontario  
M2H 3N7

**Honeywell Europe S.A.**

3 Avenue du Bourget  
1140 Brussels  
Belgium

**Honeywell Asia Pacific Inc.**

Room 3213-3225  
Sun Hung Kai Centre  
No. 30 Harbour Road  
Wanchai  
Hong Kong

---

**Honeywell**